

INNOVATIVE HYGIENIC PUMPING SOLUTIONS

HYGIENIC PUMP PROGRAM

Centrifugal pumps
Rotary lobe pumps
Twin screw pumps
Circumferential piston pumps
Air operated double diaphragm pumps
Peristaltic pumps



- ✓ Best cleanability
- ✓ Certified quality
- ✓ Innovative pumping solutions

GET IN TOUCH

With the hygienic pump manufacturer

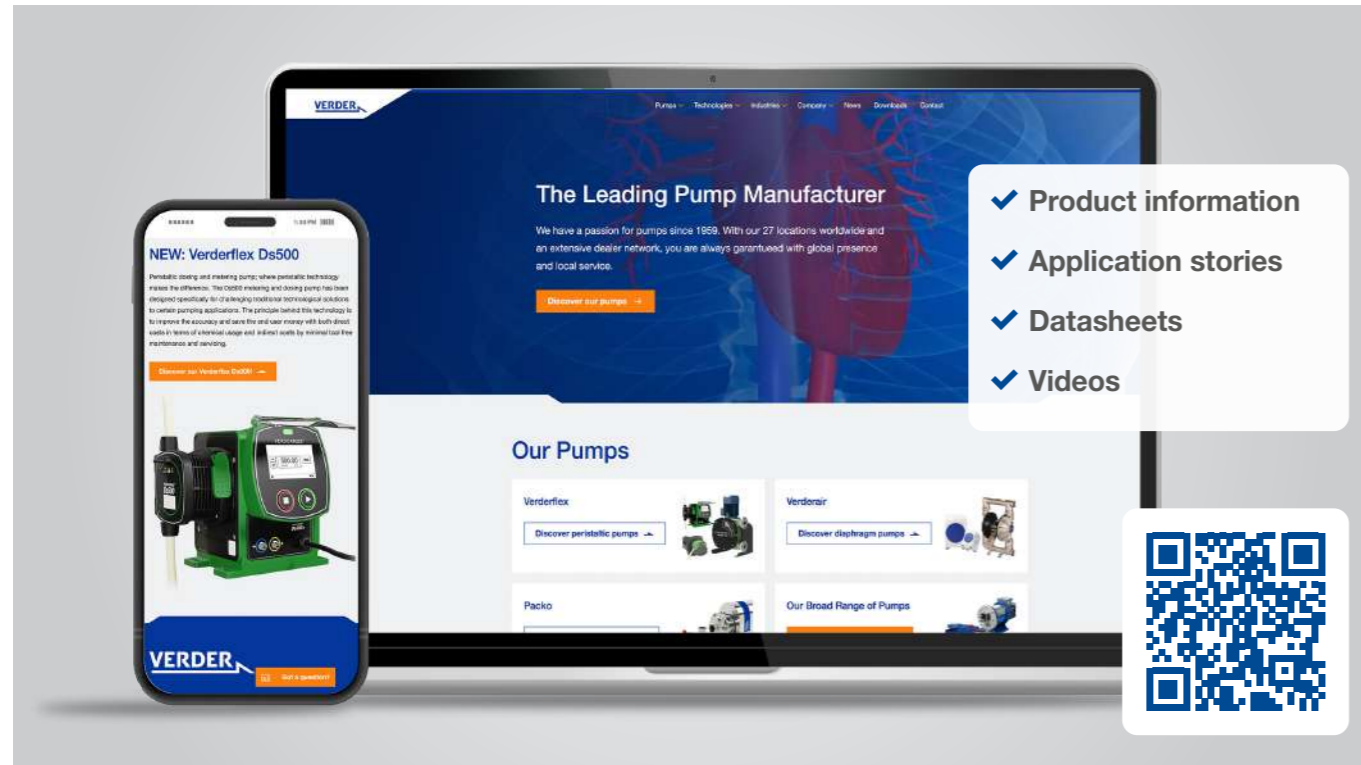

Contact VERDER

If you would like to know more about VERDER hygienic pumps then please visit our website www.verderliquids.com where you will find the full breakdown of our pump range as well as application stories, latest news and technical datasheets and more.

VERDER LIQUIDS BV

Utrechtseweg 4A
3451 GG Vleuten
The Netherlands
info@verderliquids.com
www.verderliquids.com

To provide you with the best possible service VERDER is supported by a distribution network that covers all five continents and is continuing to expand. Our group of distributors includes members of the VERDER GROUP and experienced independent companies. Our worldwide distribution network also help to provide our customers local support and spares availability.

THE VERDER GROUP

Enabling progress



The VERDER group is a family owned business formed over 60 years ago in the Netherlands; the group consists of a worldwide network of production and distribution companies. Group companies are involved in the development and distribution of industrial pumps, pumping systems, high-tech equipment for quality control, research and development into solid material (solids sample preparation and analytical technologies). The VERDER group employs over 2.000 people and has an annual turnover in excess of 450 million Euros.

- 1 Company
- 27 Countries
- > 60 Years of expertise
- > 20 Manufacturing companies
- Global network
- Local presence
- In-house service & maintenance
- A solution for every application
- In-depth knowledge of processes and applications

Throughout the decades, our value-adding innovations have been fueling our success and the success of our customers. We operate a network of more than 70 sales and manufacturing organizations worldwide, providing sales support and technical service, and ensuring customer proximity, which is vital for offering spot-on as well as establishing and maintaining long-term trustful partnerships.

With our pumping equipment we help enabling progress by for example,

- Ensuring safe food for everyone
- Keeping healthcare agile and responsive
- Making airports and travel safe

Our DNA

Our DNA is the foundation upon which our business principles are built. It forms the basis for our approach to our clients and all actions that result from this. It is as vital for us as the passionate search for technological and organizational improvements. With these core principles in mind, we help enabling progress. With continuous improvement techniques, in production processes and in the quality of life in the world.

We act as one family and know our responsibility for the society as a whole. With passion, responsibility, always aiming to improve, and an open eye for details.

ENABLING PROGRESS.

APPLICATIONS IN HYGIENIC INDUSTRIES

VERDER offers a wide program of pumps for hygienic applications in the food, pharma and dairy industry. Examples of the processes where our pumps operate successfully are listed below. Of course, there are many other areas in the hygienic market where our pumps can be applied.

Dairy

pages

Collection, storage & unloading	14, 23
Filtration	12, 16, 22
Evaporation	12, 16
Heat treatment	12, 16, 18
CIP	12, 14, 18, 26
(Waste) water treatment	12, 24, 26



Beverage

pages

Hot brewing process	12, 18
Cold beer brewing process	12, 18
Filtration	12, 18, 22
CIP	12, 14, 18, 26
(Waste) water treatment	12, 24, 26



Vegetables & potatoes

pages

Destoning, washing, cutting	12, 22
Transport of vegetables	22
Blanching	12
Frying	23
CIP	12, 14, 18, 26
(Waste) water treatment	12, 24, 26



Food / Feed

pages

Mixing/dispersing	20
Brine injection	12, 14, 16
Fish & shellfish handling	22
Egg white/yolk handling	16, 18
Animal blood handling	12, 16, 18
Animal feed systems	22
CIP	12, 14, 18, 26
(Waste) water treatment	12, 24, 26



Biotech/Pharma/Cosmetics

pages

Distilling	12, 14, 26
Purifying	12, 26
Injection	12, 26
Filtration	12, 14
CIP	12, 14, 18, 26
(Waste) water treatment	12, 24, 26



HYGIENIC DESIGN PRINCIPLES & CERTIFICATIONS



EC 1935/2004

European regulation about food materials and articles intended to come into contact with food. Guidelines about the traceability and the use of materials that do not deteriorate the colour, flavour, smell or taste of the properties of the food.



Additional regulation on top of EC1935/2004 is the EC10/2011 for plastic materials and articles intended to come into contact with foodstuffs. It concerns a.o. ion exchange resins, rubber and silicones.

ASME BPE

Standard for the design and construction of equipment used in the manufacturing of biopharmaceuticals and pharmaceutical industry.



The European Hygienic Engineering and Design Group has defined European standards for process equipment in hygienic environments. It concerns cleanability, engineering and design of process equipment.



This American standard specifies criteria for the design and fabrication of equipment that comes into contact with food. The guiding purpose of 3-A sanitary standards is to protect public health by using sanitary certified equipment.



ATEX is a European Directive (2014/34/EC) for explosion-proof electrical and mechanical equipment, components and protective systems. It concerns the manufacture of products which are used in potentially explosive atmospheres.



The American Food and Drug Association is an organization that gives references for food and pharmaceutical products to stipulate and classify substances that are compliant.



The United States Pharmacopeia (USP) has defined the minute standards to safeguard the quality of medicines and other health care technologies for pharmaceutical and bio-technology industries. There are guidelines for quality, purity, strength and consistency.



Minimum Efficiency Index, guideline for efficiency of pumps. This index gives a percentage from the sold pumps in the market on a certain moment with a low hydraulic efficiency on BEP. From 01/2015 MEI \geq 0.4. 95% of our centrifugal pumps complies to MEI.

SUPERIOR FINISHING GRADES



Every hygienic industry has its specific expectations and above all critical finishing requirements. PACKO has 3 major finishing grades with matching couplings for the centrifugal pump range so that the pumps can very easily meet the necessary certificates within these specific industries without being overspec in terms of cost.

Industrial/basic food finishing

- Rough finishing of internal welds
- Industrial couplings (EN 1092-1, BSP, ANSI and more)
- Electropolishing

Hygienic finishing

- Hand polished internal welds
- Hygienic couplings (DIN 11851, Tri-clamp, SMS, RJT and more)
- Electropolishing

Pharmaceutical finishing

- Hand polished wet pump parts up to a minimum roughness of 0.4 μ m, pharmaceutical couplings (Tri-clamp, and more)
- Electropolishing

Electropolishing: a superior finish

Most austenitic steel alloys contain iron, 18% chrome and 8% to 10% nickel. The rich metals chrome and nickel are responsible for the chrome oxide skin which gives stainless steel a high corrosion resistance. By electropolishing, which is an anodizing process where the treated objects are hung anodically in baths filled with electrolyte and electric current. The chemicals dissolve the impurities and iron. By this process, the ratio of chrome and nickel on the surface improves, making the stainless steel chemically very inert due to the development of a chromium oxide layer on the surface. This results in a lower average roughness which makes products more difficult to adhere and avoids bacterial traps and increases the cleanability. In addition, the surface is given greater resistance to corrosion.

THE HYGIENIC PROGRAM

Offering a wide range of hygienic solutions



PACKO standard centrifugal pumps



PACKO prime centrifugal pumps



PACKO dedicated centrifugal pumps



PACKO shear pumps and Verdemix



PACKO rotary lobe pumps



PACKO circumferential piston pumps



PACKO Twin screw pumps



VERDERAIR air driven diaphragm pumps



VERDERFLEX peristaltic dosing pumps



VERDERFLEX hygienic hose pumps



VERDERAIR electrical diaphragm pumps

OUR PRODUCTION COMPANIES

VERDER offers pumps that bring working solutions to customers such as making your production line smoother, safer and more reliable. VERDER pumps are synonymous with quality, longevity and reliability, operating across the globe in some of the most challenging environments and demanding of projects.

The quality and build of VERDER pumps is a result of over 60 years of designing and manufacturing pumps and gaining the knowledge and understanding of industrial processes to continuously refine and improve our offering.

We are rightly proud of our production companies, with VERDER brands being produced in 6 locations in Germany, United Kingdom, Belgium, Poland, South Korea and Italy. In-house pump production allows us to be more responsive to customer demands, assures the shortest lead times and maintains greater control over quality and costs.

As a result, VERDER is able to meet and surpass our customer expectations. For fulfilment of all your pumping requirements, we added a selection of A-brands to our product portfolio.

All our factories produce according to ISO 9001 standards.

PACKO – Belgium / South Korea

Our manufacturing company PACKO specializes in stainless steel centrifugal pumps, rotary lobe pumps and Twin screw pumps. PACKO is creating the highest quality hygienic and sanitary pumps for industrial, food and pharmaceutical applications. The centrifugal pumps are manufactured in Belgium. All centrifugal pumps are electropolished according to an in-house developed process method for surface treatment of stainless steel.

The method is finished with hand polishing techniques to achieve the highest quality pump specification for applications where compromise is not an option. Started in 1975 with dairy pumps, PACKO Pumps has developed its portfolio to include models for many certified processes including FDA, 3A and EC1935/2004.

The rotary lobe pumps and Twin screw pumps are manufactured in South Korea.

With a dedicated team and investment in advancing technology, VERDER can offer its PACKO pumps as a premium option for compliant applications. The Diksmuide plant produces not only pumps but also static and dynamic mixers.



VERDERFLEX - UK

The VERDERFLEX range includes our tube pump range which is manufactured at our Castleford Factory in the UK. These peristaltic ranges of pumps have a strong control and liquids handling capability and can utilise 'single use tubing' to ensure industry compliance. At this facility we have our own Engineering and R&D teams including the software programming side for the unit's control software and system integration in terms of the Vantage 5000 tube pump. This site manufactures peristaltic tube and hose pumps which cover all major industries from waste water treatment, chemical dosing, pharmaceutical through to food production and mining.

Ponndorf – Germany

For more than 50 years, Ponndorf has developed and produced high quality hose pumps. The range of lubrication-free hose pumps are renowned for their rigid and solid construction. Ponndorf hose pumps are in use in numerous industries, such as in the food & beverage industry, the chemical and pharmaceutical industry, paper dye industry, surface coating, water and wastewater treatment.

Metplast – Poland

Our VERDERAIR Pure machined double diaphragm pump is manufactured at the Metplast production location in Poland, according to the very highest production standards. In this modern production location everything is focused towards maintaining the highest standard of quality with a stringent protocol of testing. Metplast also produces our Babco sump pumps.

Logistic Center – Groningen

We have set up a 10,000 m² logistics center in Groningen, The Netherlands, aimed to centralize the distribution of VERDER Pumps in Europe. This ensures quick distribution of our pumps; In Europe even with "next day delivery" and to customers worldwide.

The logistics team's mission is to ensure that the pumps reach the customer in time and in a perfect condition. As our business grows, the team continuously research how to improve our production and distribution, keep costs low and maintain the high standards we have set for ourselves and for our customers.

OUR HYGIENIC PUMPS

Key players with highest hygienic standards

The hygienic pumps from VERDER are problem solvers for the hygienic market. We offer a high quality program of hygienic pumps, each having its own special advantages in specific application areas. Most pumps in our hygienic portfolio are manufactured in industrial, food or pharmaceutical versions. Our portfolio is extensive; we can offer a pump solution tailored to your specific hygienic process.

PACKO centrifugal, rotary lobe and twin screw pumps

PACKO is specialized in hygienic pumps. Centrifugal, rotary lobe and Twin screw pump cover almost all application in situations where a hygienic pump level is required.

VERDERAIR HI-CLEAN pumps

VERDERAIR HI-CLEAN is a complete series double diaphragm pumps; air operated or electrically driven, which fits the application best.

VERDERFLEX peristaltic pumps

VERDERFLEX hygienic peristaltic pumps are perfect pumps for applications where additives are being dosed. Full control of dosing applications in the hygienic market.



Corporate Qualities

- Priority orders
- Worldwide network
- Specific OEM features
- Own manufacturing
- In house engineering



Support

- Digital pump selector
- Standard spare parts
- Strong logistic services
- Worldwide stock available

Finishing levels

- Finishing grades
Industrial - Food - Pharma
- Hose & tube qualities
FDA CFR 21- EC/1935-2004
USP Class VI
Platinum Cured Silicone



PACKO STANDARD CENTRIFUGAL PUMPS

This pump series can meet the high requirements of EHEDG and 3A certification. They excel in hygienic cleanability, reliability and are easy to handle. All PACKO centrifugal pumps are configured to order, offering a huge range of pump configurations. The standard pumps are used in demanding applications such as dairy, food & beverage and pharmaceutical. This series is also perfectly applicable in industrial applications such as mining, chemicals and waste water. In fact at all duties where a high corrosion resistance is required.

All of these pumps are available in industrial, food and pharmaceutical finish.



PACKO Standard	FP60	FP1	FP2/3	MFP 2/3
Concept	Economic	Value for money	Continuous duty	High flow
Max. flow [m³/h]	40	55	320	1800
Differential head [mwc]	27	37	120	75
Min. internal surface roughness [µm]*	0,8	0,8 (impeller 3,2)	3,2	0,4
Certifications*				

* highest possible levels

PACKO PRIME CENTRIFUGAL PUMPS

The PACKO prime pumps are a range of pumps especially configured for CIP return applications and truck unloading. Used in the most demanding applications in dairy, food & beverage but also in more industrial applications where liquid air-gas mixtures have to be pumped. Everywhere where a self-priming capability is required.

Depending on the liquid, gas/air quantity, solids laden fluids, and the self-priming or air-handling requirements there are models available as:

- pump with static degasser or an air screw
- side channel pump
- centrifugal liquid ring vacuum pump

All of these pumps are available in industrial, food and pharmaceutical finish.



PACKO Prime	CRP	MSCP	MSP2	GFP
Concept	Centrifugal	Side channel	Self-priming	Defoaming
Max. flow [m³/h]	150	50	70	400
Differential head [mwc]	75	80	43	30
Internal surface roughness [µm]*	0,4	3,2	3,2	3,2
Certifications*				

* highest possible levels



PACKO ROTARY LOBE & CIRCUMFERENTIAL PISTON PUMPS

Each series of the PACKO rotary lobe and circumferential piston pumps is state-of-the-art. The pumps can be fitted with a variety of features and rotors to adapt to almost all hygienic pumping tasks. The pumps can be customized to meet the optimum function or performance to your process.



	ZL	ZP	ZW	ZLC
Concept	Rotary lobe pump	Circumferential piston	Wine pump	Pharmaceutical lobe pump
Max. flow [m ³ /h]	100	42,5	18	100
Max. discharge pressure [bar]	20	15	6	20
Internal surface roughness [μm]*	0,6	standard 0,6 (option 0,4)	0,6	0,4
Certifications*				

* highest possible levels

The Packo rotary lobe pumps are developed and engineered for specific applications, such as:

✓ Cheese curd pump

The Packo ZL560 is probably the biggest cheese curd pump made to gently handle the product without damaging the curd particles.

✓ Transfer of wine

The ZW pump is executed with PE rotors to prevent galling from grape skins, seeds and stem.



ZL560
Cheese curd pump
12 l/rev
4
0,6



PACKO ROTARY LOBE PUMPS

PACKO's range of rotary lobe pumps includes a variety of types and models, each representing the state of the art in its specific application. The pumps are available in a wide variety to suit your specific application. PACKO rotary lobe pumps are a valuable addition to the existing PACKO pump program because of their balanced seal assembly and the strong shaft construction. They are the preferred solution for applications with pressures over 12 bar.



	55	ULTIMA	HP	LT
Concept	Rotary lobe- ultra clean	Rotary lobe - heavy duty	Rotary lobe - Bi-wing	Rotary lobe - tanker
Max. flow [m³/h]	44	44	131	41
Max. discharge pressure [bar]	20	15	15	15
Internal surface roughness [µm]*	< 0,5	< 0,5	< 0,8	< 0,8
Certifications*				

* highest possible levels

✓ Truck unloading

The LT Rotary lobe pump ensures high flow, fastest loading time and lightweight truck applications in hygienic or industrial areas.

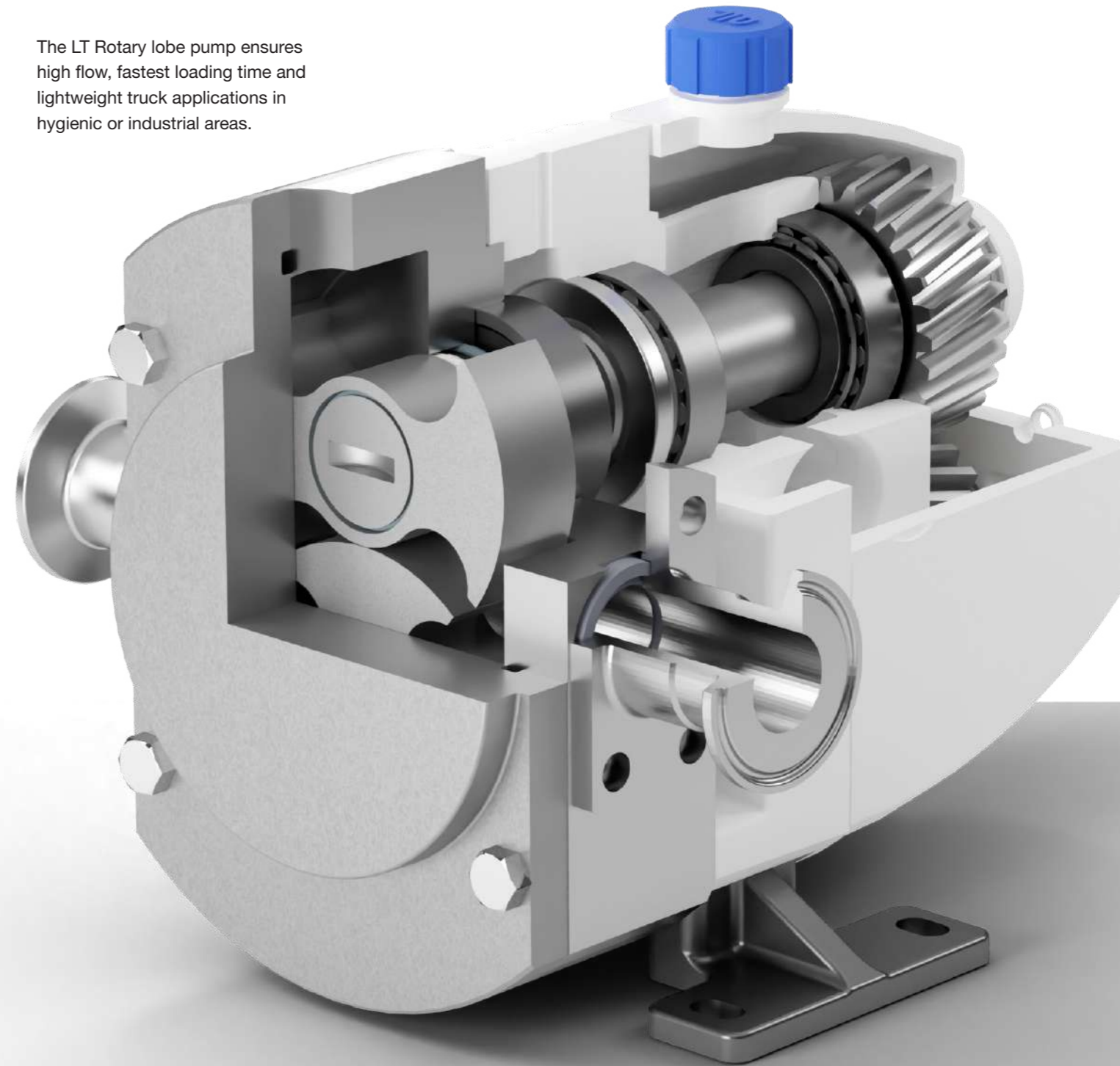



PACKO TWIN SCREW PUMPS

All advantages of rotary lobe pumps and centrifugal pumps are combined in the PACKO Twin screw series. This two-in-one operation pump series is excellent for pumping not only high-viscous liquids and pastes but also the thin-liquid cleaning fluids that are used for CIP cleaning. The pumps provide a pulsation free flow for gentle operation.

The PACKO Twin screw series offers highest flexibility, the hygiene standard is unmatched in this product area. The ZS sets the standard, the use of stainless steel in combination with optimally shaped and easy to clean surfaces is a huge benefit in any modern food production. The inner values are polished surfaces with a quality of <math><Ra\ 0.6\mu m</math>. Smooth transitions and large curves prevent product build-up and simplify cleaning and sterilization, in addition, better product handling is achieved.



	ZS	ZSC
Concept	Twin screw	Twin screw pharma
Max. flow [m ³ /h]	100	100
Max. discharge pressure [bar]	12	12
Internal surface roughness [μm]*	0,6	0,4
Certifications*		

* highest possible levels

PACKO SHEAR AND MIX PUMPS & MIXERS

The shear mix pump range consists of a high shear mixer with a patented stator for high flow and pressure and a homogenizer shear mixer for the dispersion of higher viscosities which can also be executed as a full unit. These shear mixers have the highest efficiency on the market, offering energy savings. The range is complemented with static and dynamic mixers. Shear mixer pumps and static mixers are mainly used for in-line mixing, homogenizing and disperging.

Shear mixer pumps and static mixers are the best choice when the fluids to be mixed have:

- a large difference in specific gravity
- a large different viscosity
- a difficult mixing match

This series is also perfect for dispersing of solids in liquids and gas in liquids.



PACKO Shear	SFP	JSB	Verdermix VSM	Colloid mill CM
Concept	Shear mixer	Homogenization mixer	Static mixer	Grinding & mixing
Max. flow [m³/h]	200	60	-	15
Differential head [mwc]	55	70	-	35
Internal surface roughness [µm]*	3,2	1,6	-	3,2
Certifications*				

* highest possible levels

PACKO DEDICATED PUMPS

The PACKO dedicated centrifugal pumps are developed and engineered for specific applications. It is an application dedicated pump series for:



Filtration

The FPP pump with high inlet pressure or the FMS multi-stage pump when a high outlet pressure is required.



Animal feed proces

The MWP pump which is a duplex pump with higher resistance against abrasive fluids.



Hydro transfer

The VPCP pump, a high flow pump, with the guaranteed lowest product damage on the market for the transport of e.g. vegetables such as potatoes and shellfish like mussels and prawns.

✓ Non-sealable liquids

The IM cantilever pump handles all non-sealable liquids such as hot frying oil with care.

✓ Truck unloading

The RMO centrifugal pump ensures high flow, fastest loading time and lightweight truck applications in hygienic or industrial areas.

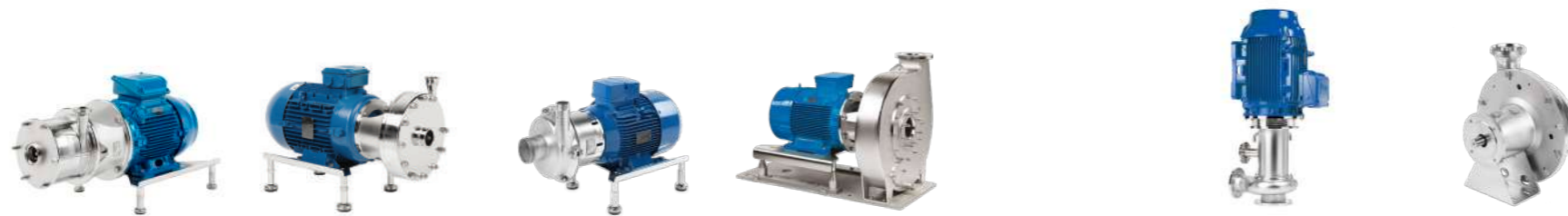
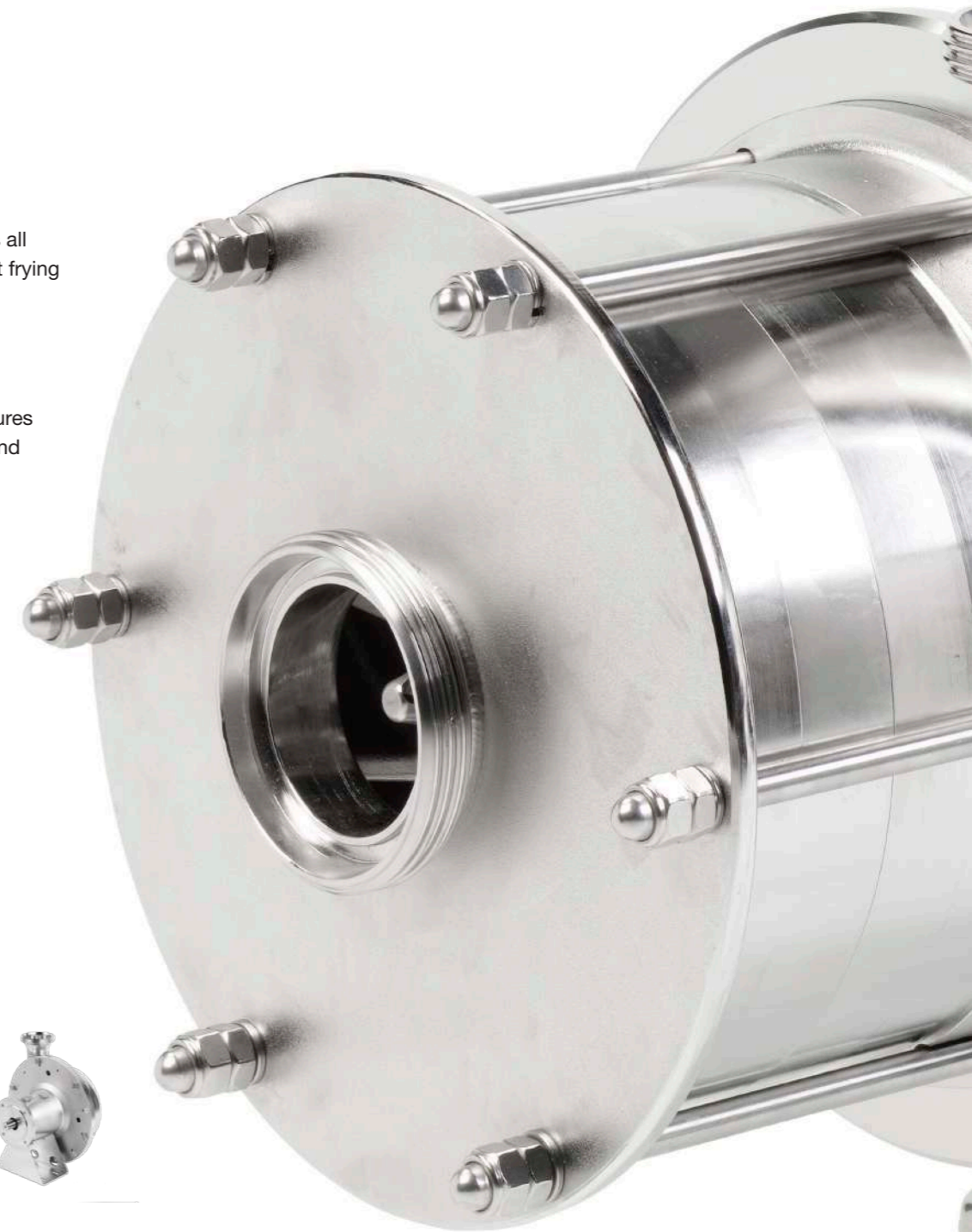

PACKO dedicated	FMS	FPP	MWP	VPCP
Concept	Multi stage	High inlet pressure	Abrasive resistant	Product pump
Max. flow [m³/h]	50	200	55	1000
Differential head [mwc]	160	70	60	20
Internal surface roughness [µm]*	3,2	3,2	3,2	3,2
Certifications*				

IM(X)L & IMO	RMO
Cantilever	Truck unloading
800	250
60	30
3,2	3,2

* highest possible levels

VERDERAIR HI-CLEAN HYGIENIC DIAPHRAGM PUMPS

The VERDERAIR HI-CLEAN pumps are designed for operation in food, beverage and pharma applications. The series consist of hygienic air operated (AODD) and electrically driven (EODD) operated diaphragm and air operated piston pumps. When compressed air is not available, a unique electrically driven series is available (EODD), with all benefits of the normal AODD series, including automatic stalling against a closed discharge line! As a second advantage the pump can run in low pulsation mode.

The single piece manifold reduces clamps and areas for food or bacteria to hide. HI-CLEAN pumps come with an externally serviceable air valve. Due to the rotatable stand the pump can rotate 360 degrees for quick draining and servicing of the pump.



✓ All series (except HC-PURE and SP) also available as electrically driven model

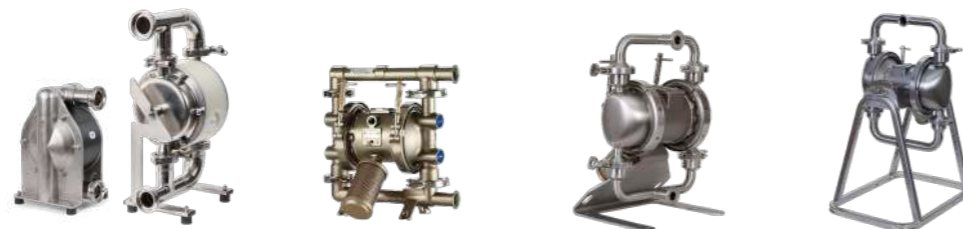

	HC-PURE High hygienic series	FDA serie FDA series	Hi-Clean Sanitary ball series	Hi-Clean Pharma series
Max. flow [l/min]	650	606	870	870
Max. discharge pressure [bar]	7	8	8	8
Max. solids particles [mm]	10	6,3	19	19
Internal surface roughness [µm]	< 0,8	3,2	0,8	0,5
Certification				

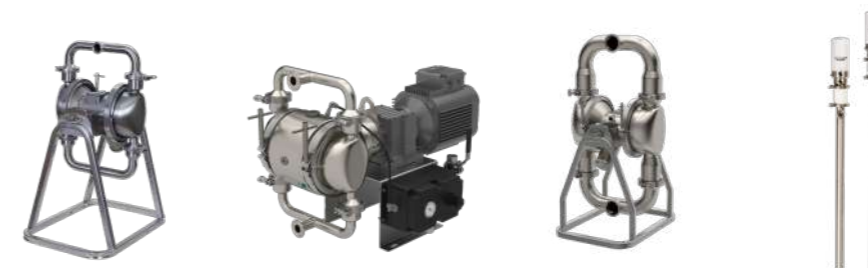

Hi-Clean 3A certified	Hi-Clean Electrically driven	Hi-Clean Sanitary Flapper	Hi-Clean SP Sanitary Piston
870	378	340	9,5
8	7	8	17
19	96,5	96,5	19
0,8	0,8	0,8	0,8

VERDERFLEX HYGIENIC PERISTALTIC PUMPS

VERDERFLEX peristaltic pumps are manufactured in ISO 9001, ISO 14001 and ISO 18001 accredited facilities in Germany and the UK. VERDERFLEX pumps are used for precise, gentle, aseptic transfer of shear sensitive cultures, nutrient dosing, inter-reactor transfer using USP VI rated tubing.

The Vantage 5000 combines precision dosing with advanced compliance assistance including time stamped record keeping, security from USB backed up settings and records and reassurance of real time feedback and control to master controllers and PLCs. It is a perfect solution for precise and controlled single or batch inline dosing/filling applications. The Rollit hose pumps are lubrication-free. This gives advantages in food and pharma applications because there is no contamination possible; even extending to our new Rollit Thru which gives the option of larger bore continuous tubing in this range of pumps allowing end-to-end process control.



	Vantage 5000	Rapide	Rollit
Concept	Advanced dosing/metering system	Compact transfer	High flow
Max. flow	6,600 ml/min	17 l/min	6,9 m ³ /h
Max. discharge pressure [bar]	7	2	2
Functions	<ul style="list-style-type: none"> Record keeping Digital communication Analog feedback and control 	Basic transfer at set speed	Can be inverter controlled
Food or pharma graded tubing and hoses*	<ul style="list-style-type: none"> Platinum cured Silicone Verderprene 	<ul style="list-style-type: none"> Platinum cured Silicone Verderprene 	Verderprene
Certifications			

*interchangeable with most other tubing brands

✓ High accuracy

The peristaltic range gives the options of easy batch tube change, minimum maintenance, and with the Vantage 5000 up to +/- 1% accuracy on a fully controlled dose/metering or transfer application for Single Use Tubing.

✓ Interchangeable tubing

Our tubing is interchangeable with all other major tubing suppliers as long as the ID/OD and properties are similar.



Rollit Thru
Single use tube batch production
125 (l/h)
1-2
<ul style="list-style-type: none"> Single use tubing 4 position pump head
<ul style="list-style-type: none"> Platinum cured Silicone Verderprene
-

